

DESCRIPTION

Solenoid valve 2 way normally closed with servo-assisted diaphragm

CONSTRUCTION

Body and cover	Brass
Armature tube	AISI 303
Plunger and core	AISI 430FR
Springs	AISI 302
Seal material	NBR - FPM - EPDM



FEATURES

- Minimum differential pressure 2.2÷7.2psi
- Maximum fluid viscosity 25cSt (mm²/s)
- Ambient temperature: from +14°F to +176°F according to the coil
- Preferred mounting position with vertical coil above

OPTIONS:

- Manual override
- Electroless nickel plating
- Series 7 explosion proof coil according to
 - ⊕ ATEX II 2G Ex mb IIC T6, T5, T4 Gb
 - II 2D Ex mb IIIC T85°C, T100°C, T135°C Db similar to NEC 505 Div.1 Class II IIC T6
- Version with slow closing diaphragm
- Version for vacuum applications (air/gas)

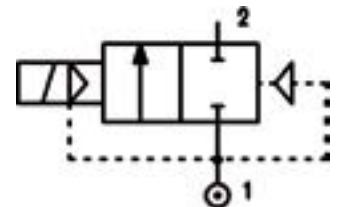

4

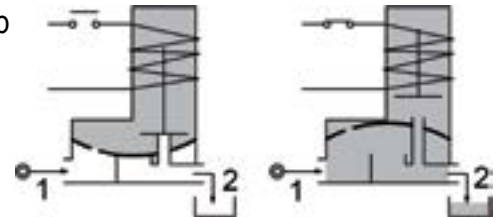

CODE	Port Size	Orifice Size		Flow Factor Cv	Operating Pressure Differential (M.O.P.D.) ④						Nominal power			Coil		Seal	Temp. range
					Min		Max				AC (VA)	DC (W)	Series	Width (mm)			
					(psi)	(bar)	AC (psi)	AC (bar)	DC (psi)	DC (bar)							
① ② E107BN...10///...	1/4	0.394	10	1.73	2.2	0.15	217	15	217	15	12	8	6.5	3	22	NBR=B EPDM=E FPM=V	+14 +194 +14 +284 +14 +284
E107CN...10///...	3/8	0.394	10	1.97	2.2	0.15	217	15	217	15							
E107CN...12///...	3/8	0.472	12	2.54	2.2	0.15	217	15	217	15							
E107DN...12///...	1/2	0.472	12	2.89	2.2	0.15	217	15	217	15							
E107EN...18///...	3/4	0.709	18	6.36	2.2	0.15	188	13	188	13							
E107FN...25///...	1	0.984	25	11.79	2.2	0.15	145	10	145	10							
E107GN...30///...	1-1/4	1.181	30	17.34	2.2	0.15	145	10	145	10							
③ E107CN...12/W...	3/8	0.472	12	2.54	7.2	0.5	360	25	360	25	15	11	8	4	30	NBR=B	+14 +194
③ E107DN...12/W...	1/2	0.472	12	2.89	7.2	0.5	360	25	360	25							

- ① Seal Ordination example: E107DNB12///U351 NBR seal, connection 1/2 NPT
- ② Coil Coil 24V DC certified and marked
- ③ Reinforced diaphragm
- ④ Safe Working Pressure:360 psi. Is the line or system pressure to which the valve may be subjected without being damaged. The maximum allowable pressure PS for steam is 36 psi.

COILS Code ②	Alternating Current						Direct Current				Electrical connection	Connectors	DESCRIPTION Class F or H insulation Voltage tolerance ±10% Protection class: IP65 with connector attached IP00 without connector Continuous service ED100%
	24V		120V		240V		12V		24V				
Series 3 Width 22mm	U35B c	30B	U35D c	30D	U35F c	30F	U350 c	300	U351 c	301	DIN 46244	PG9 code 10348000	
Series 4 Width 30mm	-	40B	-	40D	-	40F	U450 c	400	U451 c	401	DIN 43650A	PG9 code 10349000	

OPTIONS
Cable attached
Special coil voltage
Special coil powers

OVERALL DIMENSIONS

inches (mm)

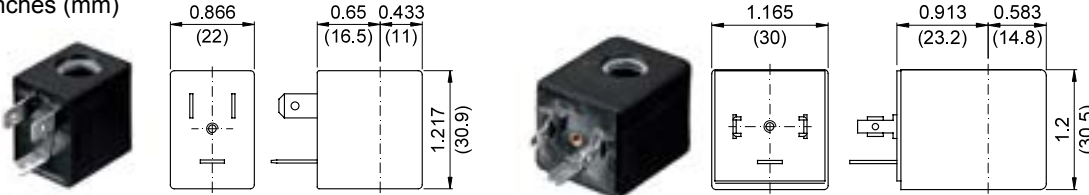

Series 3 Weight 0.11lb (0.05Kg)

Series 4 Weight 0.22lb (0.1Kg)

FOR COIL SPECIFICATION SEE SECTION 6

SPARE PARTS LIST

1. Coil fixing nut
2. Coil
3. Plunger assembly
4. Armature tube assembly
5. Diaphragm assembly

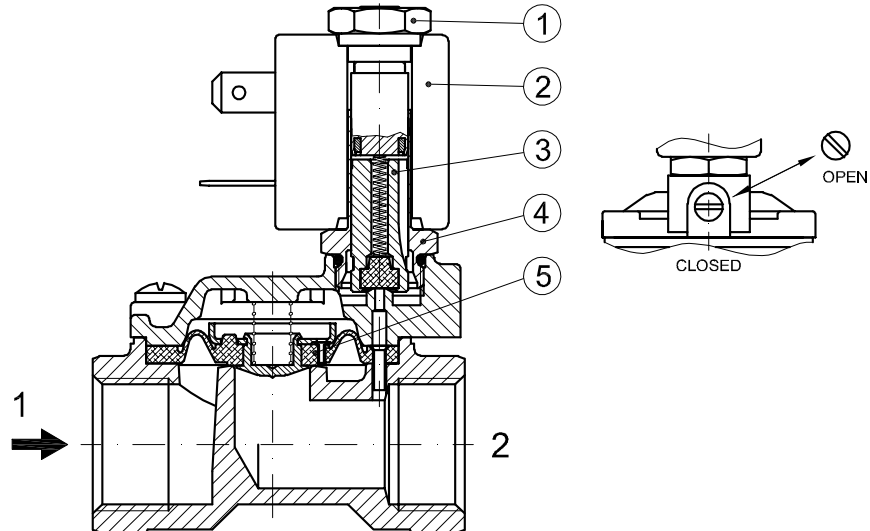

OVERALL DIMENSIONS

inches (mm)

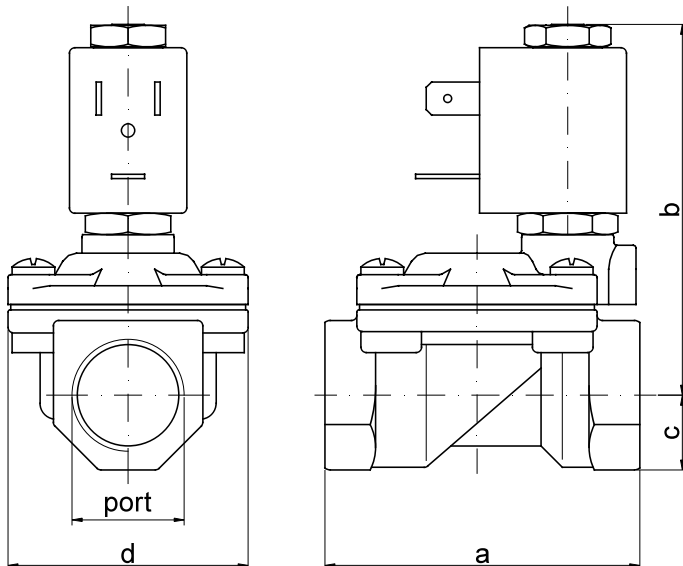

PORT SIZE	a		b		c		d		weight	
	in	mm	in	mm	in	mm	in	mm	lb	Kg
1/4 Ø0.394 (Ø10)	1.93	49	2.56	65	0.43	11	1.26	32	0.53	0.24
3/8 Ø0.394 (Ø10)	1.93	49	2.56	65	0.43	11	1.26	32	0.51	0.23
3/8 Ø0.472 (Ø12)	2.32	59	2.76	70	0.55	14	1.77	45	0.93	0.42
1/2 Ø0.472 (Ø12)	2.32	59	2.76	70	0.55	14	1.77	45	0.86	0.39
3/4	3.11	79	2.99	76	0.71	18	2.17	55	1.43	0.65
1	3.78	96	3.35	85	0.79	20	2.83	72	2.31	1.05
1-1/4 Ø1.181 (Ø30)	4.69	119	3.62	92	0.98	25	3.35	85	3.75	1.70

COILS Code ②	Alternating Current						Direct Current				Electrical connection	Connectors
	24V		120V		240V		12V		24V			
Series 2 Width 30mm	U25B c us	20B	U25D c us	20D	U25F c us	20F	U250 c us	200	U251 c us	201	DIN 43650A	PG9 code 10349000

DESCRIPTION
 Insulation class F or H
 Voltage tolerance $\pm 10\%$
 Protection class:
 IP65 with connector attached
 IP00 without connector
 Continuous service ED100%

OVERALL DIMENSIONS

inches (mm)

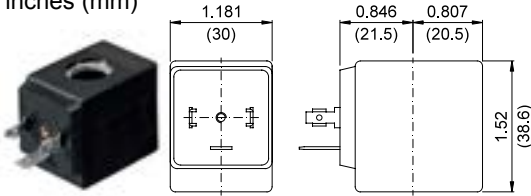

Series 2 Weight 0.26lb (0.12Kg)

OPTIONS

Cable attached
 Special coil voltage
 Special coil powers

FOR COIL SPECIFICATION SEE SECTION 6

SPARE PARTS LIST

- Coil fixing nut
- Coil
- Plunger assembly
- Armature tube assembly
- Diaphragm assembly
- Speed control valve
- Water hammering reducer
 $\varnothing 0.03$ - $\varnothing 0.039$ - $\varnothing 0.04$
 $(\varnothing 0.8$ - $\varnothing 1.2$ - $\varnothing 1.5)$

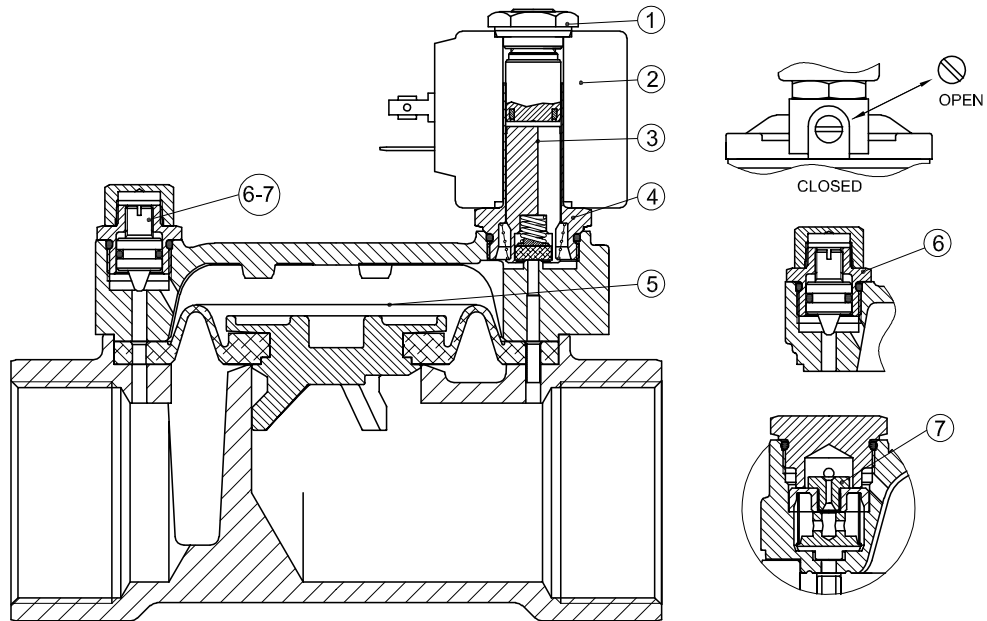

OVERALL DIMENSIONS

inches (mm)

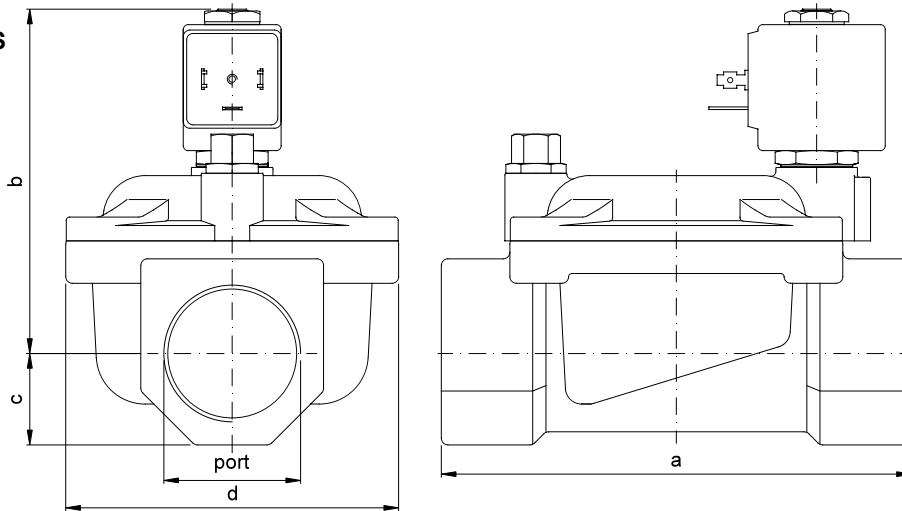

PORT SIZE	a		b		c		d		weight	
	in	mm	in	mm	in	mm	in	mm	lb	Kg
1-1/4	5.59	142	4.13	105	1.1	28	4.02	102	6.61	3
1-1/2	5.59	142	4.13	105	1.1	28	4.02	102	6.28	2.85
2	6.22	158	4.53	115	1.38	35	4.69	119	9.48	4.3
2-1/2	8.9	226	5.28	134	2.01	51	6.65	169	25.8	11.7
3	8.9	226	5.28	134	2.01	51	6.65	169	21.8	9.9