

**DESCRIPTION**

Encapsulated coil incorporating the magnetic circuit.  
 Fixing by means of a central nut.  
 Electrical connection according to DIN 43650 B  
 (B Industrial connection)



**CONSTRUCTION**

Encapsulation:  
 Class F Fibre-glass Nylon  
 Class H Fibre-glass Polyarylamide  
 Magnetic circuit Zinc-plated steel  
 Windings Copper covered with class H insulation  
 Ambient temperature: class F +14°F +131°F  
 class H +14°F +176°F  
 UL coils +14°F +140°F

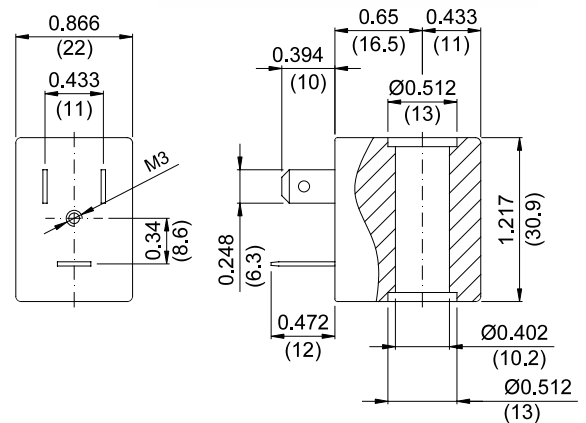

**OPTIONS:** Electrical connection through cable  
 Special powers and voltages  
 Self-extinguish

CODE		Alternating Current Voltage	Direct Current Voltage (V)	Power ①		Voltage tolerance		Connector	Service ED
Class F insulation	Class H insulation			Alternating Current (VA)	Direct Current (W)	Alternating current	Direct current		
30A	32A	12V 50/60Hz	-	8	-	+15%	-	10348000	100%
30B	32B	24V 50/60Hz	-						
30C	32C	48V 50/60Hz	-						
30D	32D	110V 50/60Hz	-						
30E	32E	220/230V 50/60Hz	-						
30F	32F	240V 50/60Hz	-						
30G	32G	380V 50/60Hz	-						
300	320	-	12	-	6.5	-	±10%		
301	321	-	24						
302	322	-	48						

Certified versions US

-	U35B	24V 60Hz	-	8	-	±10%	-	10348000	100%
-	U35D	120V 60Hz	-						
-	U35F	240V 60Hz	-						
-	U350	-	12	-	6.5	-	±10%		
-	U351	-	24						

Certified versions

-	V32E	220/230	-	8	-	+15% -10%	-	10348000	100%
---	------	---------	---	---	---	--------------	---	----------	------

① Considering nominal voltage and an ambient temperature of +68°F (+20°C)